

WEIGHING TABLE WITH GRANITE PLATE ON THE LEFT, WITHOUT REAR UPSTAND, WITH MONITOR SUPPORT, PERFORATED ON THE RIGHT, ON CASTORS, DIM. 1100X700X600Hmm



Frame structure in stainless steel AISI 304 fully welded 40x40mm tube, 1.00mm thick, rear legs 80mm advanced, suitable for rounded floor corner. Rear and side welded reinforcement rails. Working top in AISI 304 sheet, 1.50mm thick. Rounded (R=10mm) front edge, as well as rounded (R=2mm) side and back edges.

Monitor support dim. 300x70x268hMM.

Opening on the left side of the working top to allow the placement of a 400x400x40Hmm black granite plate supported by anti-vibration rubber spacers. Perforated working top on the right side, 1.50mm thick, with Ø9mm holes and 60mm wide perimeter band on the working top. On swivel castors, 2 with brake.

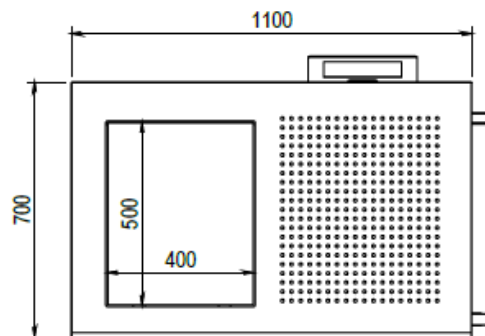
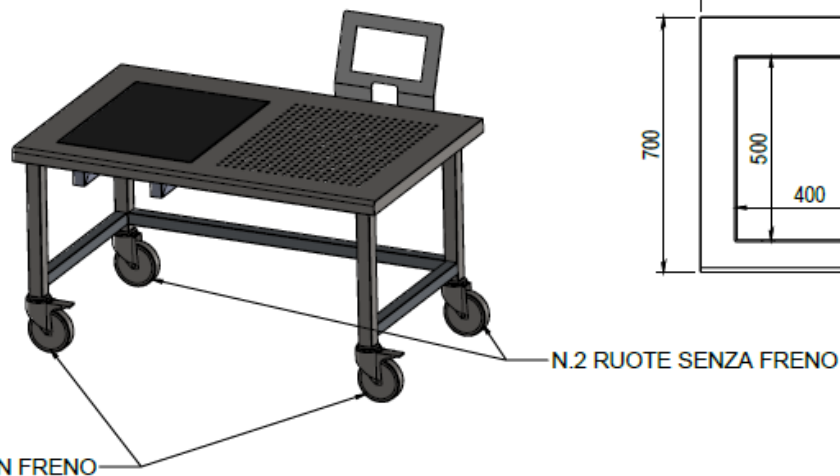
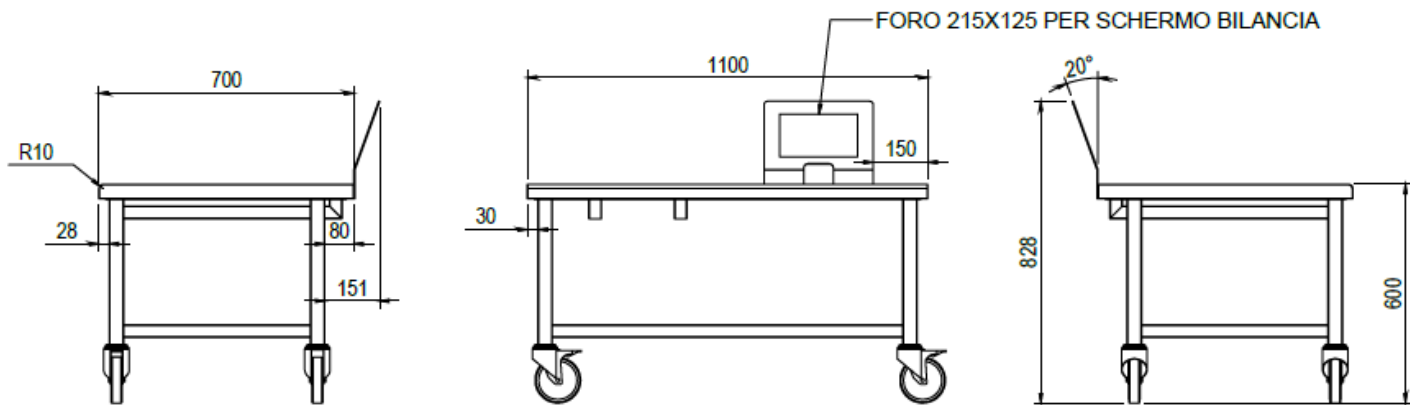

2					
1					
A	06/11/2021			PRIMA EMISSIONE	
REV	Disegnato:	Data emissione:	Approvato:	Data ultimo agg.:	Descrizione:

Note:



Tolleranza generali dimensionali:	UNI ISO 2768-mk	Scala:	1:18	Peso:	38,501 kg
		Materiale:			
		Sviluppo:		x x	
		Cliente:		Treatmento:	

Serie:	Codice articolo:	Codice cliente:
Descrizione:	Codice:	
TAVOLO SU RUOTE PER PESATURA CON PIANO IN GRANITO A SX SENZA SPONDA POST. FORELLINATO A DX. DIM. 1100X700X600H	TS21001020-000D	
		Rev.