

PACKING TABLE WITH A LOWER PART IN THE CENTER, FOLDING SHELF ON THE LEFT SIDE AND UPPER STRUCTURE FOR BOXES. DESIGNED FOR MOUNTING A ROTATING ARM. ON ADJUSTABLE FEET.



Made of stainless steel AISI 304, Scotch Brite finish, with 40x40mm fully welded frame structure, 1.00mm thick, rear legs non advanced. With lower shelf completely welded to the structure and reinforcement rails positioned halfway between shelf and working top, H=150mm, 100mm deeper than the table structure in order to house boxes. Folding shelf on the left side, dim. 400x900mm, capacity 50kg. On adjustable feet.

Working top in AISI 304 sheet, 1.20mm thick, with inner plywood reinforcement and stainless steel lower cover. Rounded (R=10mm) front upper edge, as well as rounded (R=2mm) side and back edges. 700x300mm (LxH) lower part starting at 800mm from the left side of the table.

Upper structure H=700mm, with fixed shelf and lower inclined shelf with 12 removable compartments. Right upper part complete with stainless steel plate sp. 50/10 for fixing rotating arm.

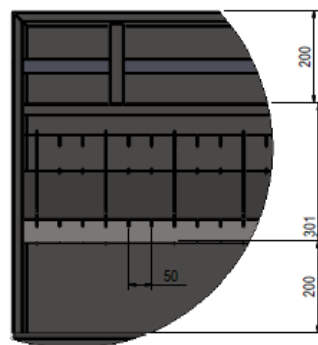
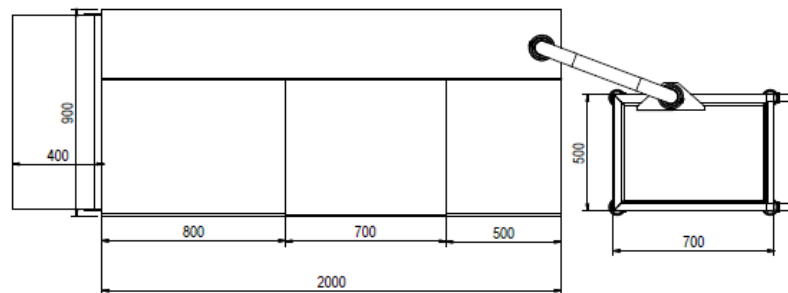
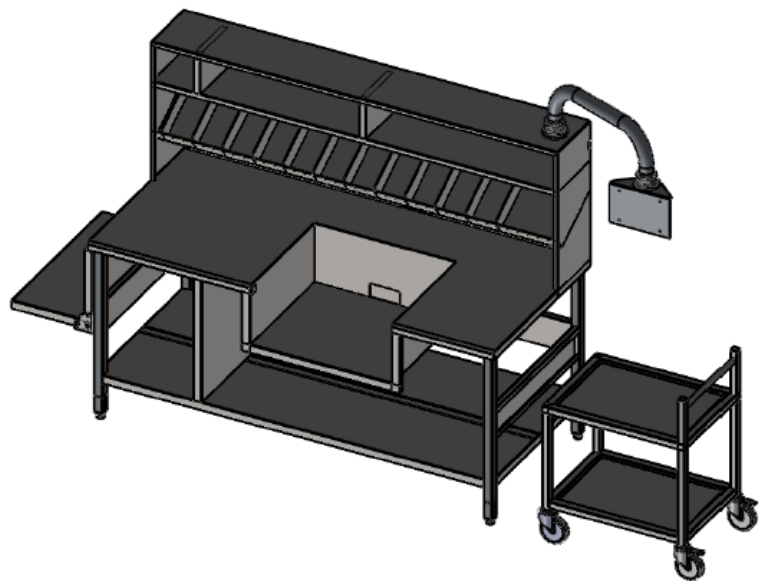
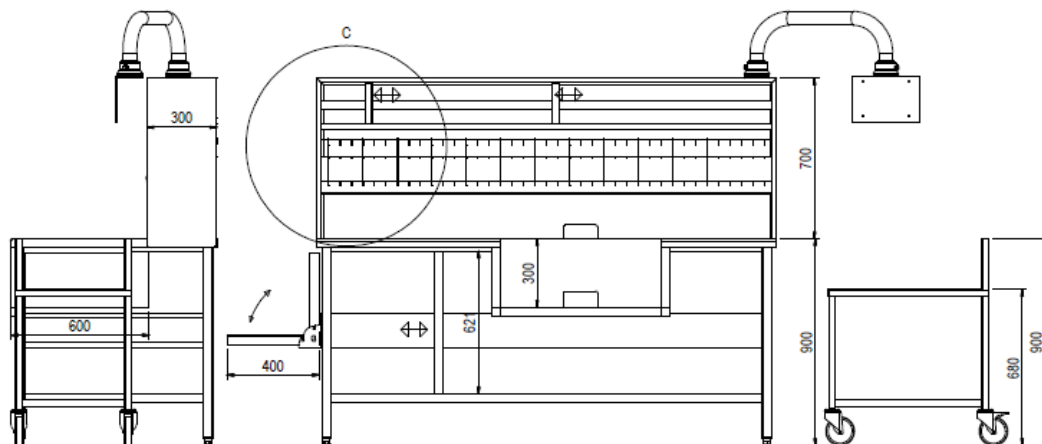
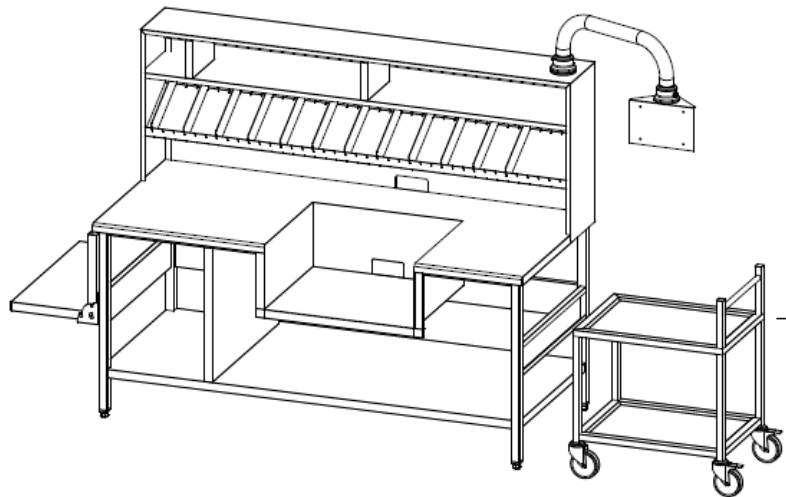

DETTAGLIO C  
SCALA 1:10

Rif.	Modifiche	Data	Firma	Materiale: AISI 304 SB
				Sviluppo: 2000X900X900H
				Trattamento:
				Peso kg. Dist.Loc. It.
				Scala: 1:20 Dist.to dal:
				Codice:
	Serie: Disegnato: Titolo:	Tolleranze generali, Dimensioni UNI ISO 2768-mk Controlato:	Data: 30/06/2016	Assieme totale tavolo imballo
	10 - ..... si riserva o terzi di legge la proprietà del presente documento con divieto di riprodurlo o divulgarlo senza sua previa autorizzazione.			