

OPEN CONSUMABLES CABINET WITH LEXAN
PANELS, 5 COLUMNS OF 5 COMPARTMENTS
EACH, ON CASTORS, DIM. 1200X350X1500Hmm

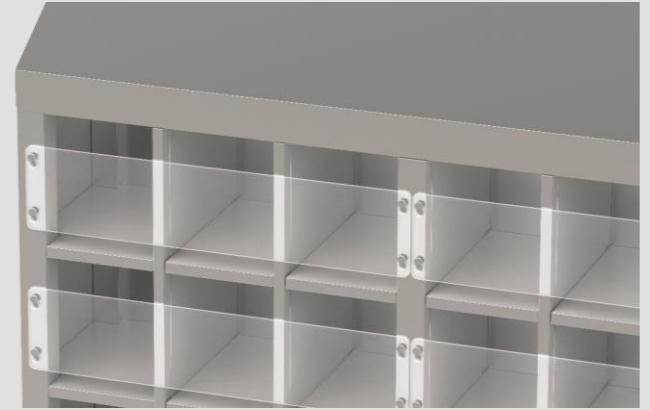

Made of AISI 304 18/10 Ni-Cr stainless steel with Scotch Brite finish. To close the open compartments there are removable transparent polycarbonate panels with upper and lower front openings for loading and extraction of consumable. On 4 swivel castors Ø125mm, with stainless steel support, two with brake, the rear ones are fixed to prevent tilting.

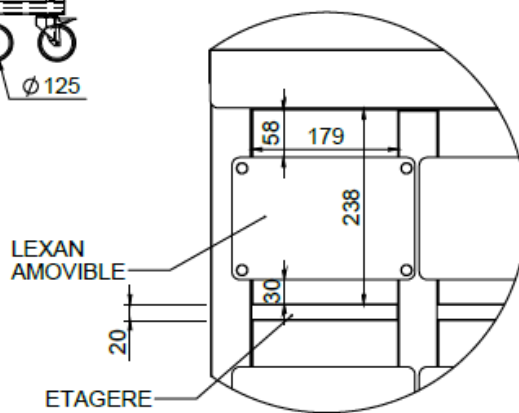
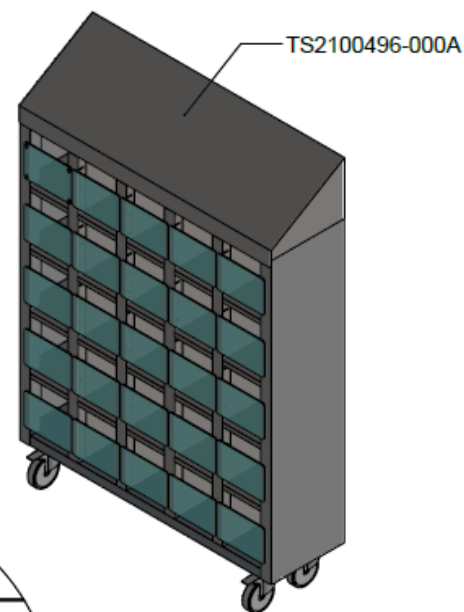
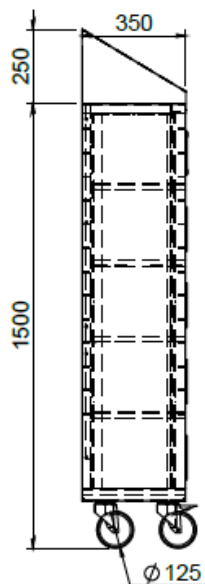
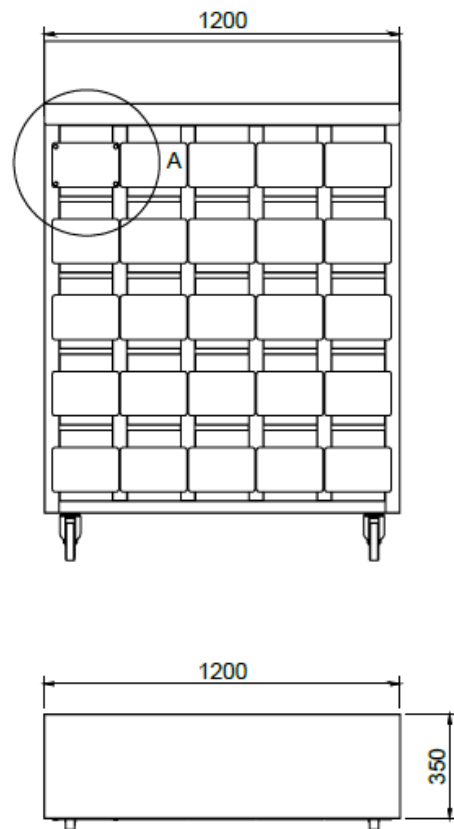

DETTAGLIO A
SCALA 1 : 8



Tolleranze generali dimensioni:	UNI ISO 2768-mK		Scala:	1:22	Peso:	148,818 kg
			Materiale:			
			Sviluppo:		x x	
			Trattamento:			

Serie:	Codice articolo:	Codice cliente:
Descrizione: ARMADIO PER CONSUMABILI A GIORNO C/PANNELLI IN LEXAN, 5 COLONNE DA 5 VANI CAD, SU RUOTE, DIM. 1200X350X1500Hmm		Codice: TS21000494-000B